

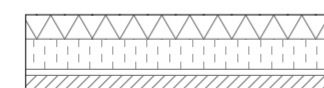

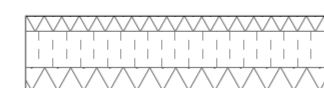

SIGNATURFORKLARING - Bygningsdele

-  508 mm tegl/isolering/letbeton
-  490 mm beton/isolering/letbeton
-  120 mm stål-gipsvægge
-  200 mm letbetonvægge
-  R Redningsåbning

SIGNATURFORKLARING - Døre

- D1 EI2 30 - Rw 37dB
- D2 Massive trædøre

▲ S-01

NOTE  
 Alle koter er i meter i henhold til DVR 90.  
 Alle mål er i mm og skal kontrolleres inden  
 produktionsopstart.

Rev nr.	Dato	Rettelse	Af	Godk.
01	12/08/15 07:44	Ændring af sokkelbredde	Michal Nielsen	

Ramsvej 5 - 4 nye lejligheder

Mair nr 193k Viborg Markjæder  
 Bygherre Bach Gruppen A/S, Industrivej 22, 8800 Viborg  
 Adresse Ramsvej 5, Viborg

Tegning Plan 0 Tegn. nr. 99.3.02